



BRAVINO™

Lightweight Stroller

Owner's Manual

Read all instructions BEFORE
assembly and USE of product.

KEEP INSTRUCTIONS FOR
FUTURE USE.





FAILURE TO FOLLOW THESE INSTRUCTIONS AND THE PRODUCT LABELS CAN RESULT IN SERIOUS INJURY OR DEATH TO YOUR CHILD.

- PLEASE SAVE OWNER'S MANUAL FOR FUTURE USE.
- ADULT ASSEMBLY REQUIRED.
- NEVER LEAVE CHILD UNATTENDED. Always keep child in view while in the stroller.
- AVOID SERIOUS INJURY from falling or sliding out. Always use safety harness. After fastening buckles, adjust belts to ensure a snug fit around your child.
- AVOID FINGER ENTRAPMENT: Use care when folding and unfolding the stroller. Be certain the stroller is fully opened and latched before allowing your child near the stroller.
- USE OF THE STROLLER with a child weighing more than 50 lbs (22.7 kg), will cause excessive wear and stress on the stroller. Use the stroller with only one child at a time.
- STROLLER TO BE USED only at walking speed. Product not intended for use while jogging, skating, etc.
- TO PREVENT A HAZARDOUS, UNSTABLE CONDITION, never place purses, shopping bags, parcels or accessory items on the canopy or handle. Do not place more than 10 lbs (4.5 kg) in the storage basket
- NEVER ALLOW the stroller to be used as a toy.
- AVOID BURNS. Never put hot liquids in cup holder. Do not place more than 3 lbs (1.4 kg) on the parent tray/cup holder.
- DISCONTINUE USING THE STROLLER if it is damaged or broken.
- AVOID STRANGULATION. DO NOT place items with a string around your child's neck, suspend strings from this product, or attach strings to toys.
- NEVER USE STROLLER ON STAIRS or escalators. You may suddenly lose control of the stroller and your child may fall out. Also, use extra care when going up or down a step or curb.
- This stroller can be used with children up to 50 lbs. (22.7 kg).
- DO NOT attempt to attach any infant car seat to the stroller other than a Chicco infant car seat. Injury or death may result when attempting to use this stroller in conjunction with infant car seats from other manufacturers.
- Before use, remove and dispose of all plastic bags and packaging materials and keep them out of reach of children.
- Before assembly, check that the product and all of its components have not been damaged during transportation.
- Do not use accessories, spare parts, or any component not supplied or approved by Chicco as they may make the stroller unsafe.



FAILURE TO FOLLOW THESE INSTRUCTIONS AND THE PRODUCT LABELS CAN RESULT IN SERIOUS INJURY OR DEATH TO YOUR CHILD.

Using a Chicco infant car seat with the stroller:

- Child Tray must be properly attached to use a Chicco infant car seat.
- ONLY USE a Chicco infant car seat with this stroller.
- ONLY USE this product to transport infants that are within the size and weight limitations of the infant car seat.
- FALL HAZARD: Always check that infant car seat is securely attached to stroller frame by pulling up on the infant car seat.
- ALWAYS SECURE your child with the car seat harness. Always make sure child is properly harnessed in the car seat.
- Refer to your Chicco infant car seat user guide for additional warnings and use instructions before using this product.

PARTS LIST

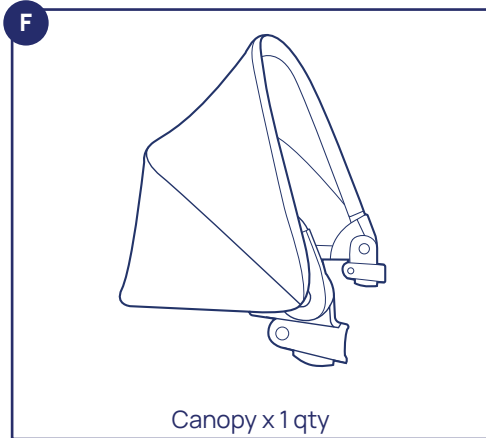
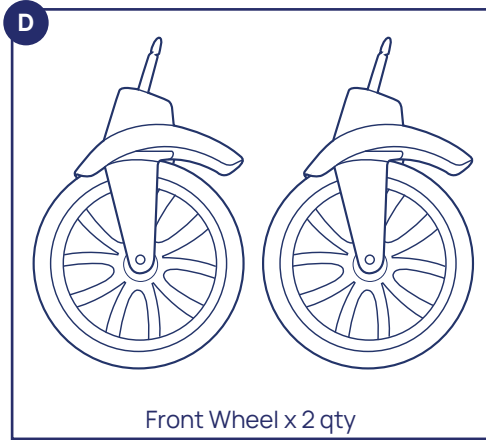
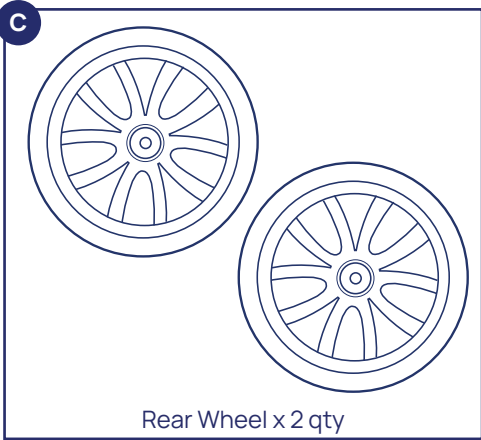
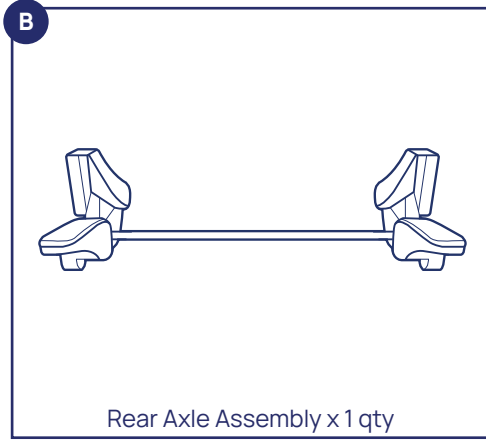
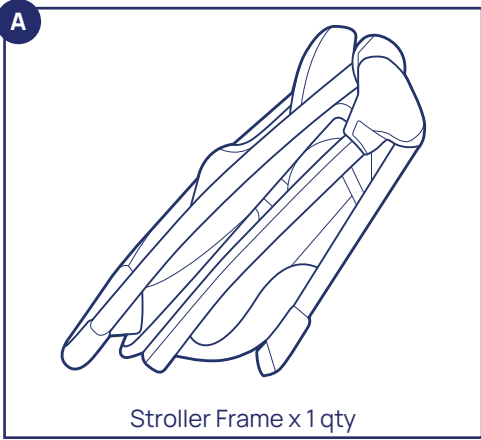

PARTS LIST

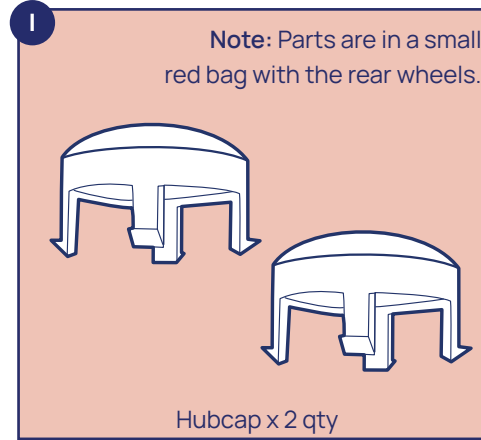
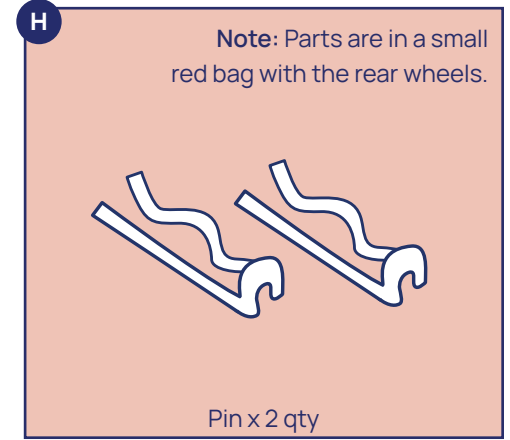
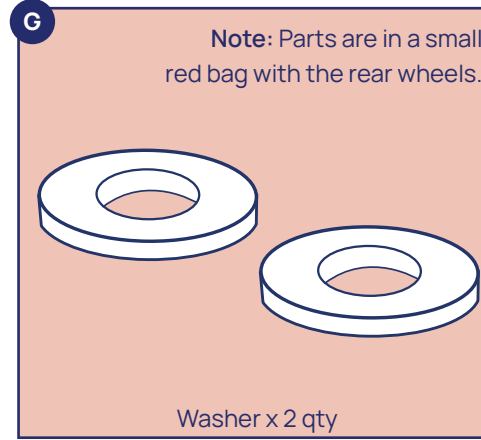

SETTING UP THE STROLLER

⚠ WARNING: When opening the stroller, ensure that all children are at a safe distance. Make sure the movable parts of the stroller do not come into contact with your child.

- 1 Stand the **stroller frame (A)** on end and unfold.

To protect your floor during setup, we recommend working on carpeted or protected area. The product carton can be flattened and used as a work surface before being recycled.

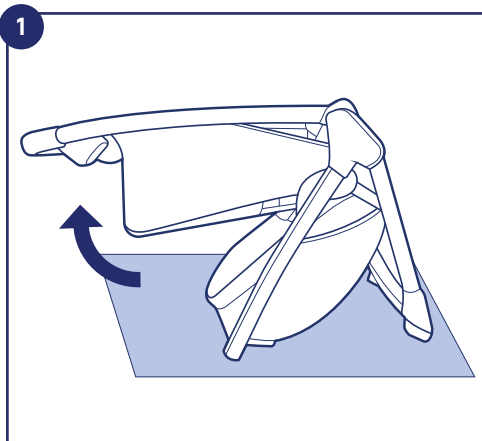

- 2 Press down firmly on the middle of the seat to make sure that the **stroller frame** is locked into the open position.

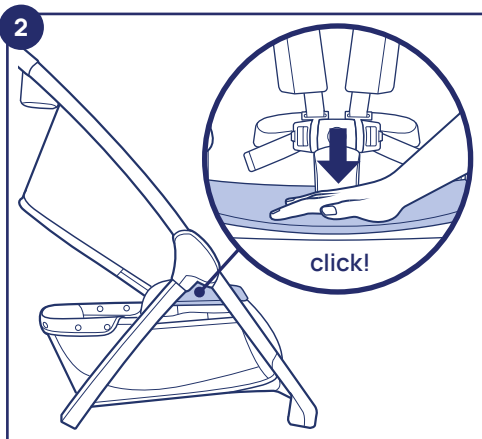

- 3 To attach the **rear axle assembly (B)**, orient the assembly with the brake pedals towards the back of the stroller and axle mounts aligned to the rear of the **stroller frame**.

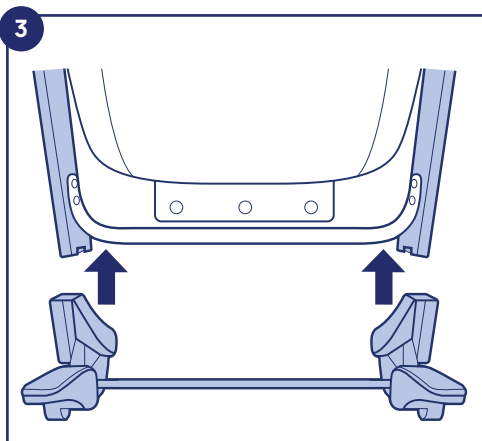

- 4 Slide the rear axle assembly onto the **stroller frame**.

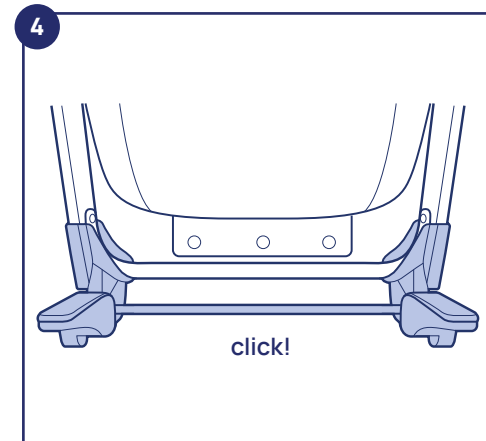

- 5 The snap buttons click into the holes on the rear axle mounts.

Make sure the **rear axle assembly** is securely attached to the **stroller frame** by pulling in the opposite direction of attachment.

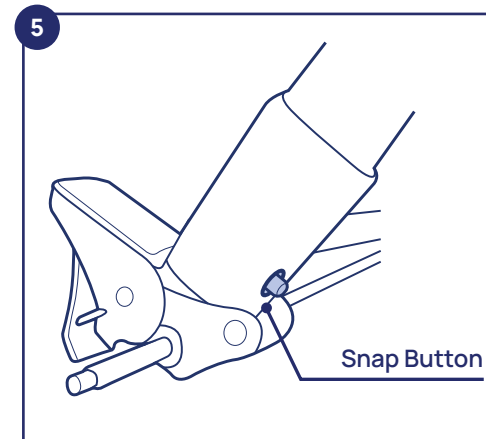

- 6 To secure the basket to the **stroller frame**, wrap the basket strap around the tube on the **stroller frame** and secure the 3 snaps to the bottom of the basket.

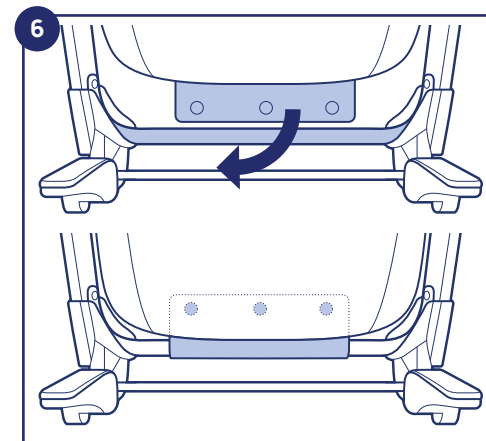

SETTING UP THE STROLLER

- 4 Slide the rear axle assembly onto the **stroller frame**.

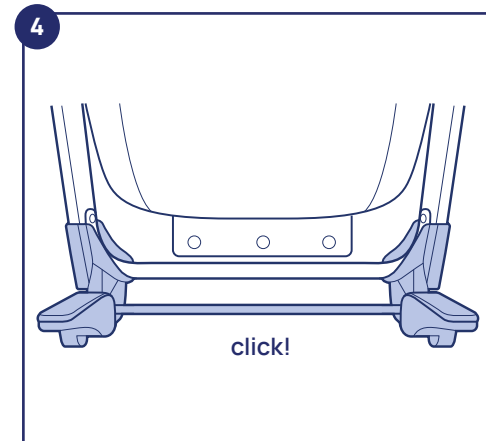

- 5 The snap buttons click into the holes on the rear axle mounts.

Make sure the **rear axle assembly** is securely attached to the **stroller frame** by pulling in the opposite direction of attachment.

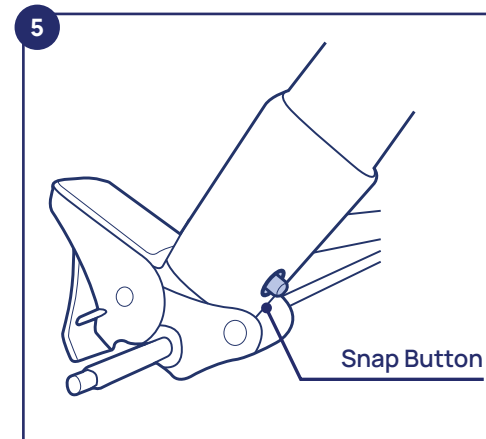

- 6 To secure the basket to the **stroller frame**, wrap the basket strap around the tube on the **stroller frame** and secure the 3 snaps to the bottom of the basket.

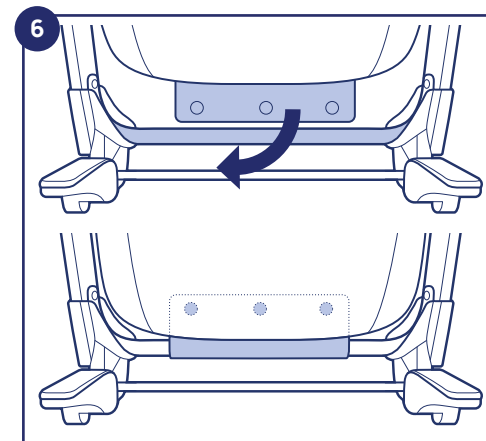

SETTING UP THE STROLLER

- 7 To attach the **rear wheels (C)** to the rear axle assembly, slide one **rear wheel** onto the axle. The **rear wheel** is fully seated on the axle when the brake lug is in contact with the rear axle mount.

It may be necessary to rotate the wheel until the brake tab fits into one of the brake grooves on the inside of the wheel.

Repeat this step for the other **rear wheel**.

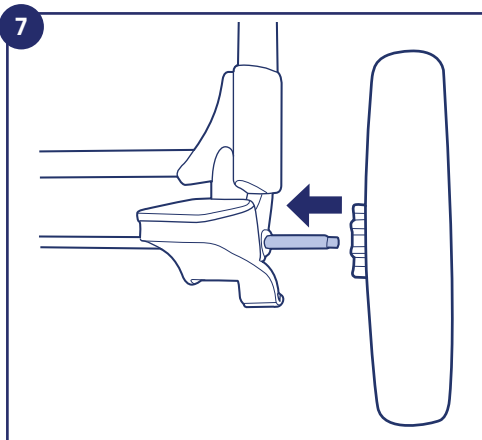

- 8 Slide a **washer (G)** onto the rear axle.

Repeat this step for the other **rear wheel**.

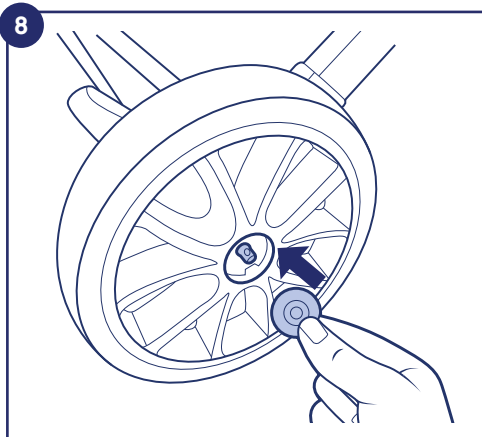

- 9 Secure the **rear wheel** to the axle using a **pin (H)**. Push the straight side of the **pin** through the hole. The curve on the **pin** must curve around the outside.

Make sure the wheels are secure by pulling the wheels in the opposite direction of attachment.

Repeat this step for the other **rear wheel**.

⚠ WARNING: Check that the rear wheels are secured correctly.

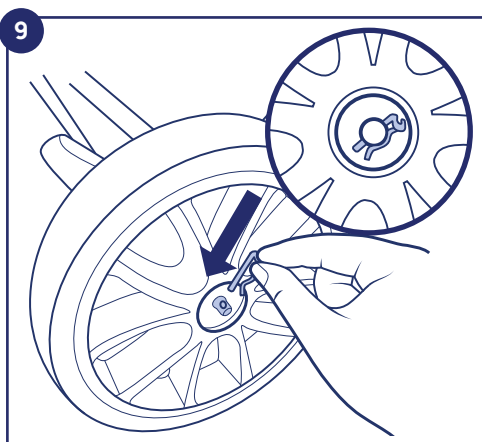

- 10 Line up the tabs on a **hubcap (I)** to the notches in the **rear wheel** and insert the **hubcap** until it snaps into place.

Repeat this step for the other **rear wheel**.

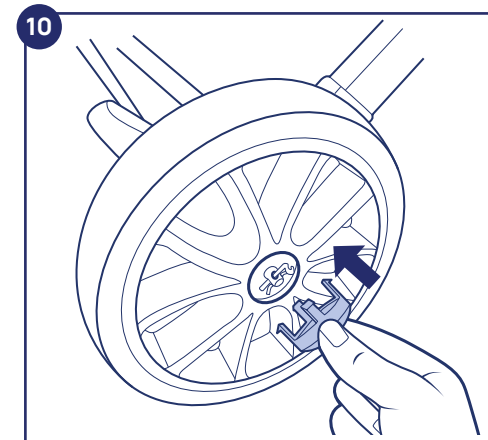

- 11 To attach the **front wheel (D)**, line up the front wheel post to the socket and insert the **front wheel** until it clicks.

Repeat this step for the other **front wheel**.

Make sure the wheels are secure by pulling the wheels in the opposite direction of attachment.

⚠ WARNING: Check that the front wheels are secured correctly.

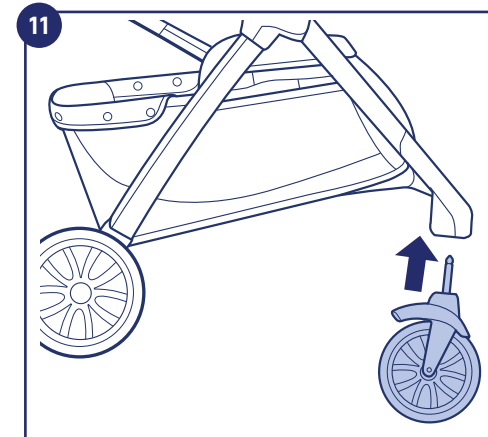

- 12 At the front of the basket, insert the hook and loop straps on the basket through the slots on the back of the footrest and secure them under the basket.

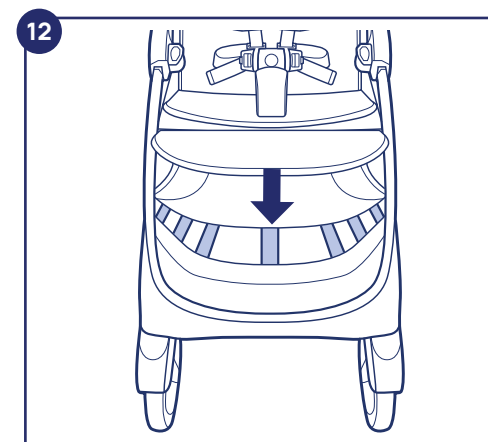

SETTING UP THE STROLLER

- 13** To attach the **canopy (F)**, line up the **canopy** to the **stroller frame** so that the Chicco label is to the front and the tab on the canopy clip is rotated to the back of the frame.

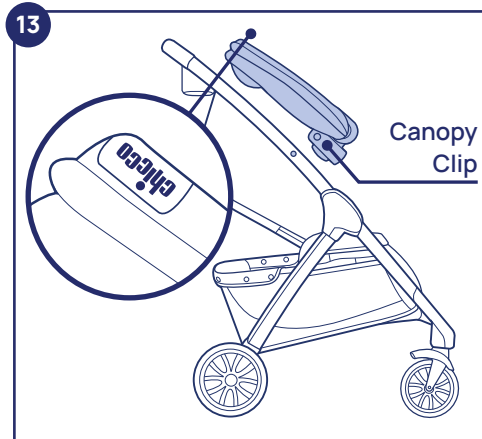

- 14** Attach the **canopy** by clipping both canopy clips to the **stroller frame**.

Make sure the button on the **stroller frame** is centered in the hole in the canopy clip and that the clips click in place on the frame.

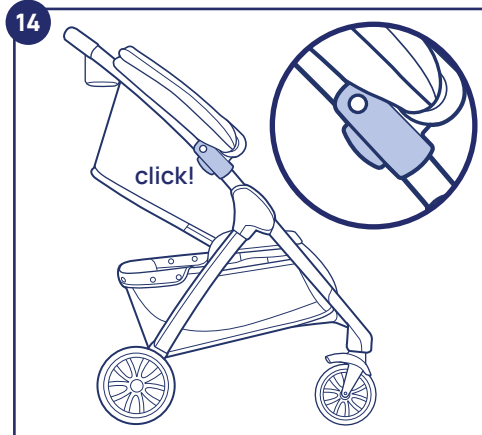

- 15** To extend the **canopy**, pull the front edge of the **canopy** forward.

Close the **canopy** by pulling the front edge back.

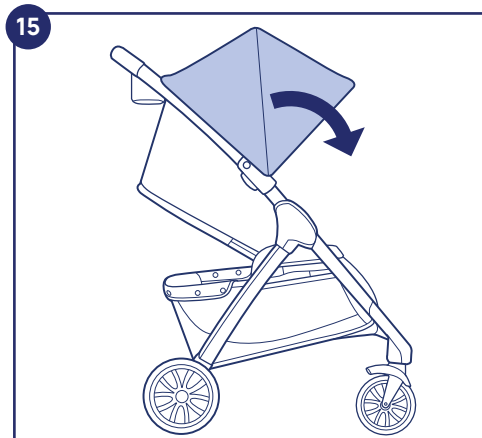

- 16** The **canopy** has an additional flip-out visor for extra coverage.

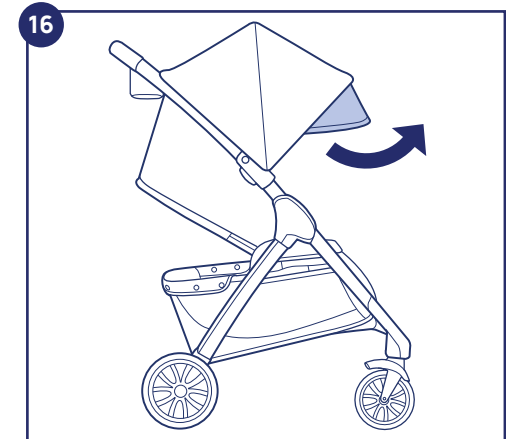

- 17** The **canopy** can be rotated completely forward with an additional flip-out visor on the back for extra coverage.

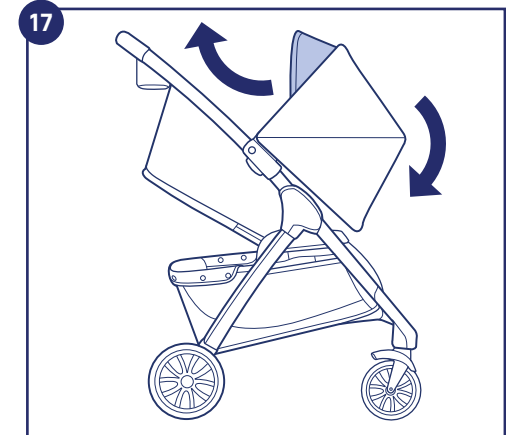

- 18** To remove the **canopy**, release the canopy clips by pulling out on the tab on the back edge of the canopy clips.

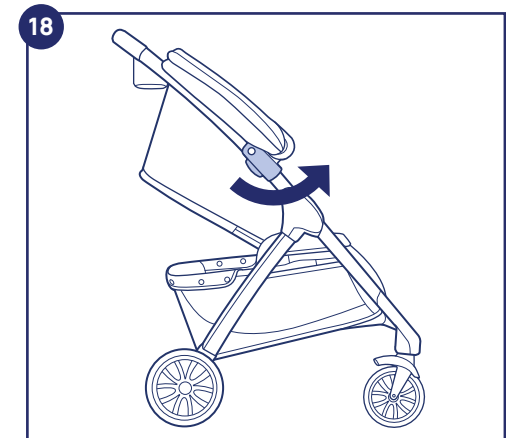

SETTING UP THE STROLLER

- 19 To adjust the backrest to a lower position, squeeze the recline lever on the back of the seat and lower the backrest until it latches into the desired position.

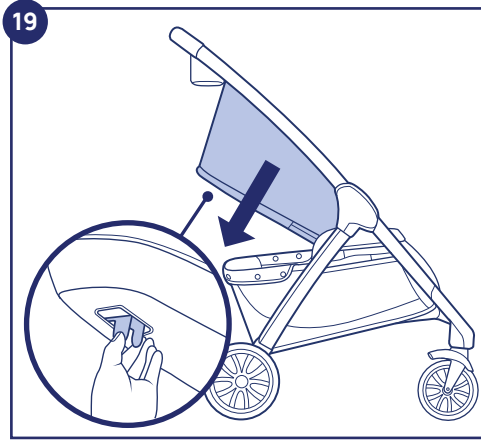

- 20 To adjust the backrest to an upright position, push up on the backrest until it locks into the desired position.

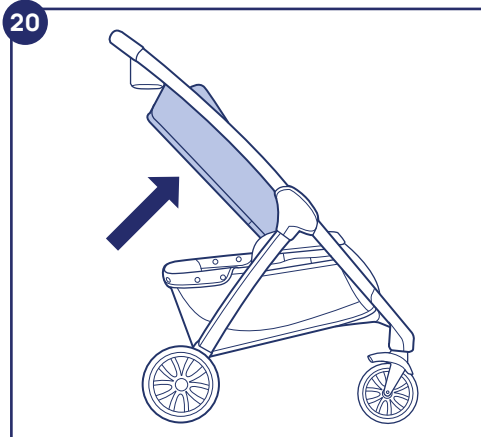

- 21 To attach the **child tray (E)**, line up the child tray posts to the sockets on the **stroller frame**. Insert the child tray posts into the sockets until they click.

Make sure the **child tray** is securely attached by pulling the tray in the opposite direction of attachment.

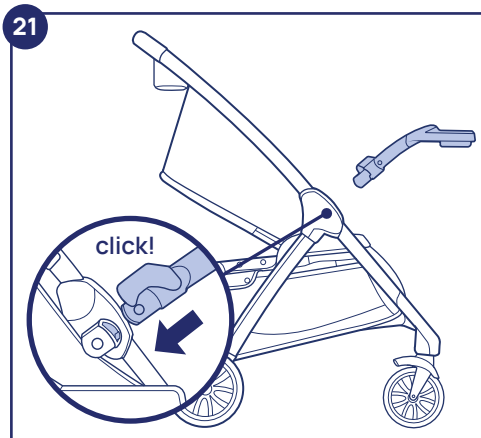

- 22 To remove the **child tray**, press in on the release buttons located on either side of the **child tray** and pull out.

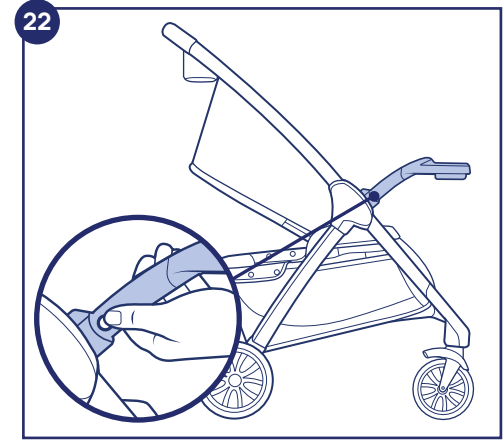

- 23 To extend the adjustable leg rest, rotate the leg rest up to the level of the seat until the latches engage.

The basket can be accessed from the front of the stroller when the footrest is in the locked upright position.

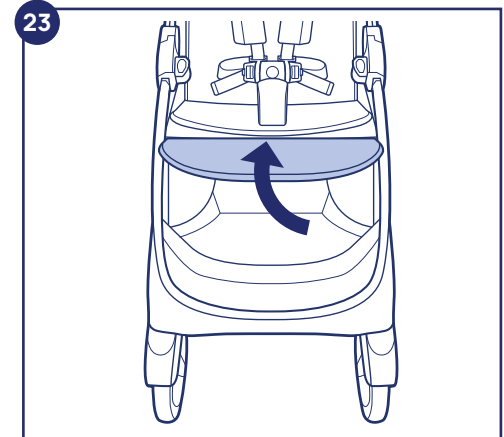

- 24 To fold the leg rest down, grasp both sides of the leg rest and rotate it above the height of the seat while pulling both levers forward.

The latches will release and the leg rest can be rotated to the lower position.

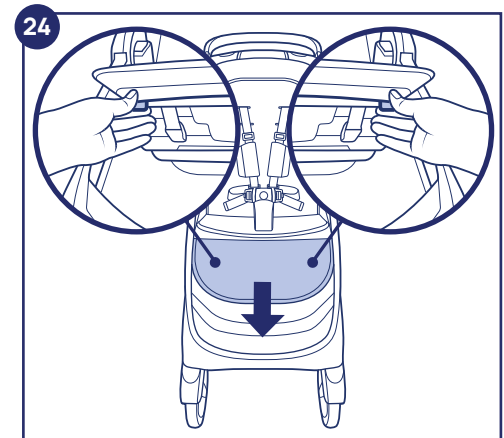

USING THE BRAKES

⚠ WARNING: Always apply brakes whenever the stroller is stationary. Never leave the stroller on a sloped surface, with a child onboard, even with the brakes applied.

- 1 To **LOCK** the brakes, step on each brake lever to rotate them down until they stop.

Ensure both brake levers are fully rotated and engaged.

- 2 Check that the brake is engaged by trying to push the stroller. If the brakes are not locked, repeat step 1.

- 3 To **UNLOCK** the brakes, lift each brake lever to rotate them up until they stop.

Ensure both brake levers are fully rotated and disengaged.

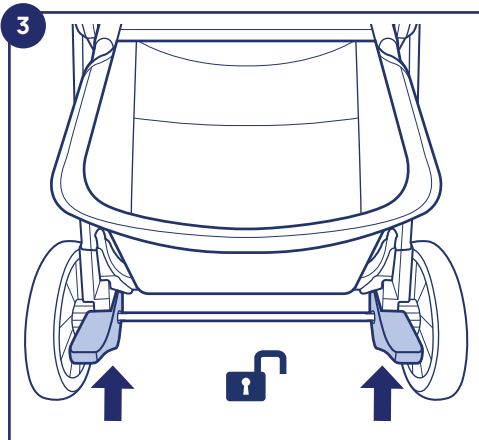
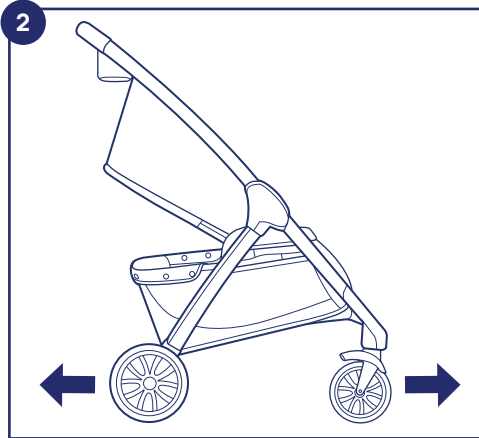
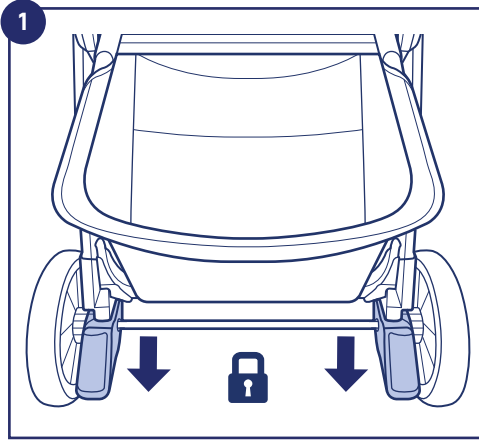

ADJUSTING THE SAFETY HARNESS

⚠ WARNING: Always use a harness position located **ABOVE** the child's shoulder line. If multiple positions are above the child's shoulder line, use the one closest to it.

- 1 The shoulder straps can be adjusted to 3 height positions.

Note: It is recommended that children under 6 months old ride in a Chicco infant car seat that is attached to the stroller to create a travel system.

- 2 To determine the correct position, place your child in the seat with their back flat against the backrest. Note the closest harness strap position that is visible **ABOVE** their shoulders.

- 3 To adjust the shoulder straps, first release the safety harness. Press the button in the center of the crotch buckle and release both waist strap clips.

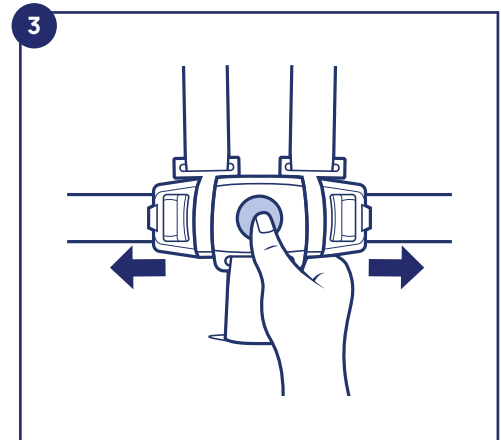
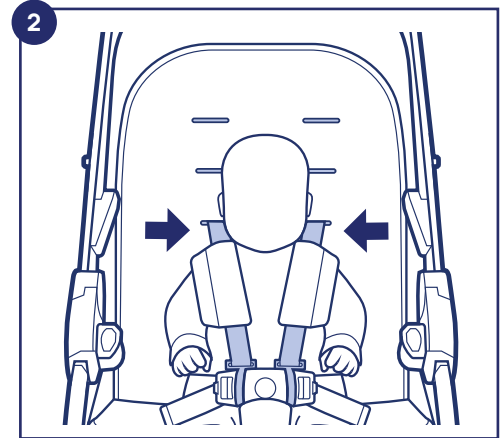
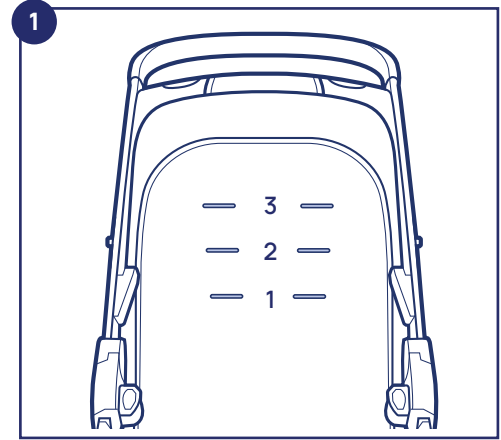

ADJUSTING THE SAFETY HARNESS

- 4 Pull up on the shoulder strap connector to unclip it from the waist strap clip.

The bottom of the shoulder strap connector is designed to break away from the waist strap clip when not secured in the crotch buckle.

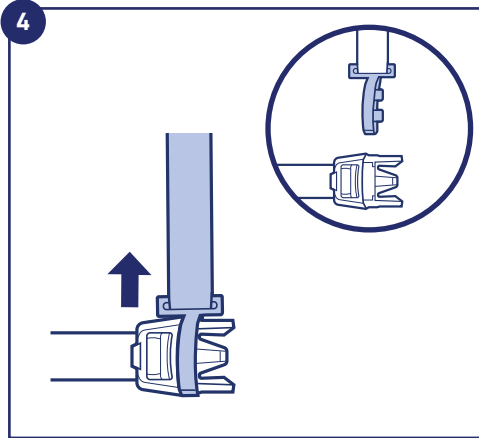

- 5 To adjust the shoulder straps, push the shoulder straps through the button hole.

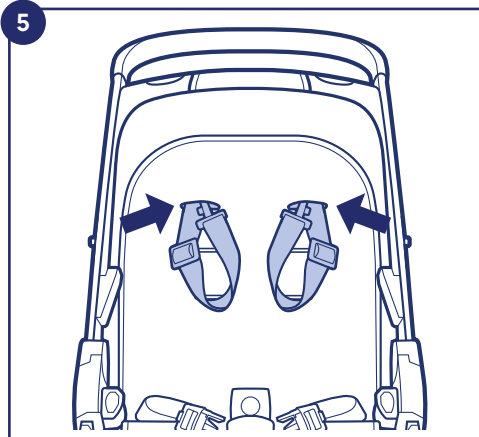

- 6 Then pull the shoulder straps back through the desired button hole.

Always use the same button hole height for both shoulder straps.

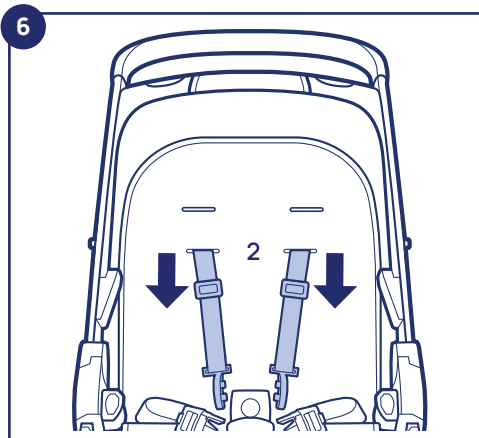

⚠ WARNING: Never leave child unattended. Avoid serious injury from falling or sliding out. Always use safety harness.

- 7 Lay the shoulder strap connector in the correct position.

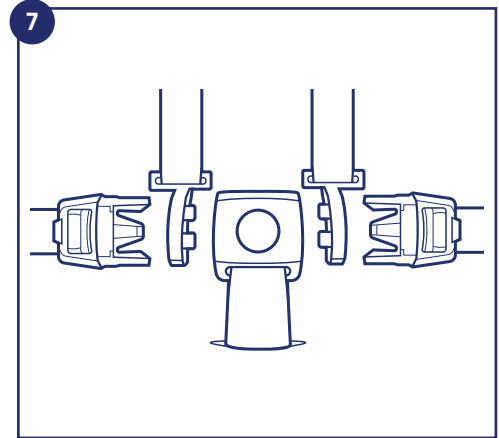

- 8 Slide the shoulder strap connector onto the waist clip. Repeat for the other side.

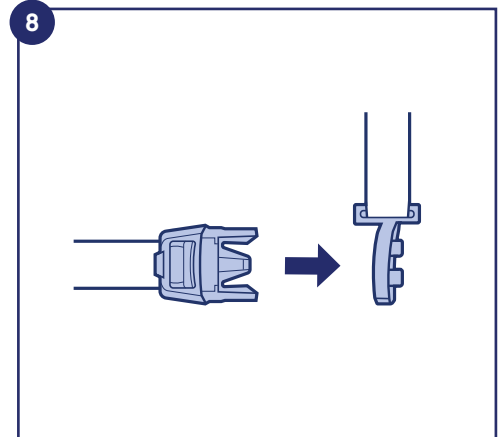

- 9 Slide the waist clip into the crotch strap buckle and listen for a click. Repeat for the other side.

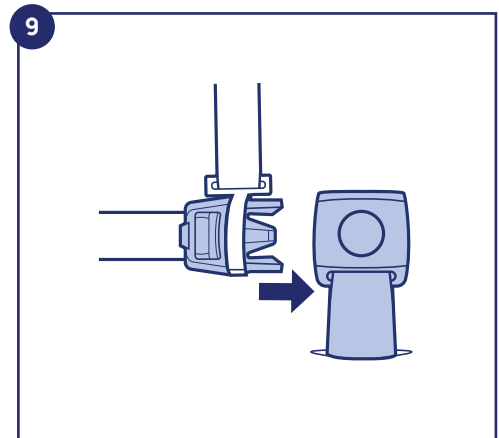

- 10 Pull both sides to make sure both clips are secured to the crotch buckle.

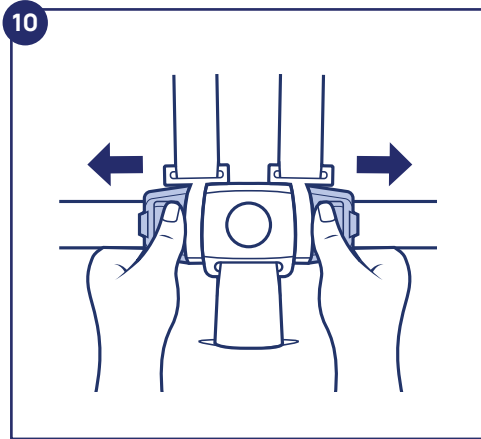

- 11 The length of the shoulder straps can be adjusted by pulling the adjustment buckles to tighten or loosen.

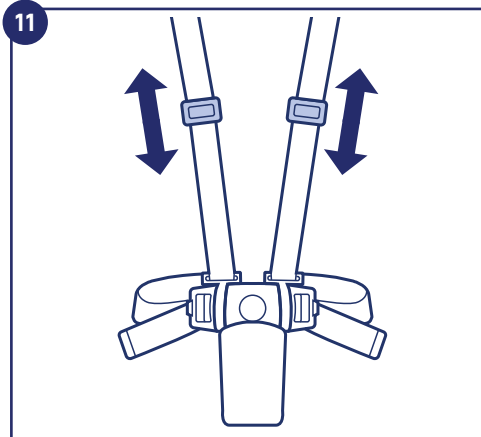

- 12 The length of the waist straps can be adjusted. Press the tab at the end of the waist clips and pull the strap to tighten or loosen to better fit your child.

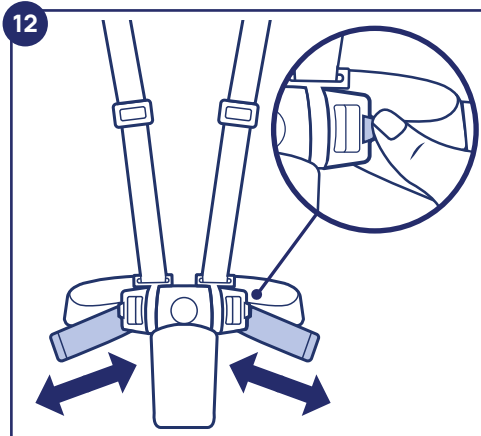

⚠ WARNING: ONLY USE a Chicco infant car seat with this product. Make sure to properly install the child tray prior to using the Chicco infant car seat. Always make sure child is properly harnessed in the car seat. Only use this product to transport infants that are within the size and weight limitations of the infant car seat. Refer to your Chicco infant car seat user guide for additional warnings and instructions before using this product.

- 1 To use your stroller with a Chicco infant car seat, attach the **child tray** to the **stroller frame** and make sure the backrest is fully reclined.

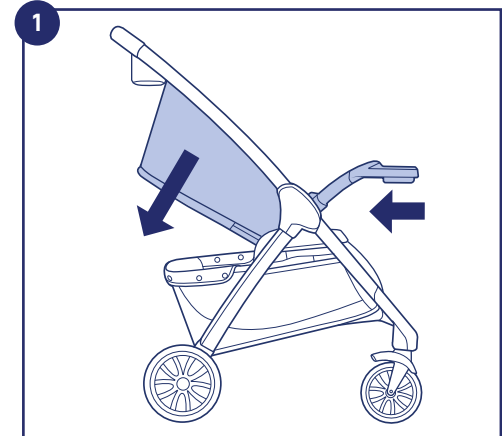

- 2 The Chicco infant car seat will only fit into the stroller **REAR FACING**. The child will be facing you when pushing the stroller.

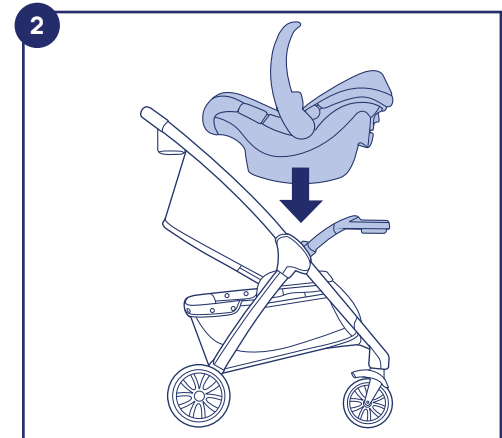

- 3** Place the Chicco infant car seat into the **stroller frame**. Make sure the infant car seat clicks into the **stroller frame** on both sides.

Note: If using the stroller canopy with the infant car seat, rotate the carry handle to allow the stroller canopy to fully extend.



- 4** Make sure the Chicco infant car seat is securely attached to the stroller by lifting up on the carry handle.

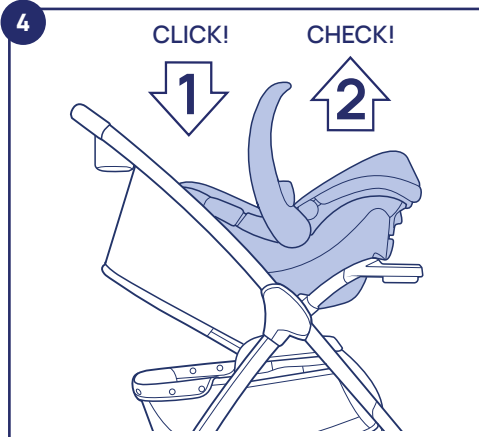

- 5** To remove the Chicco infant car seat from the stroller, squeeze the release handle on the back of the infant car seat and lift up on the carry handle.

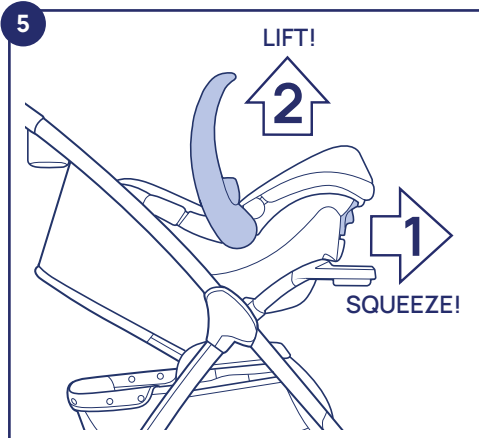

⚠ WARNING: When folding the stroller, ensure that all children are at a safe distance. Make sure the movable parts of the stroller do not come into contact with your child.

Note: The infant car seat must be removed from the stroller before folding.

- 1** To fold the stroller, apply the brakes.

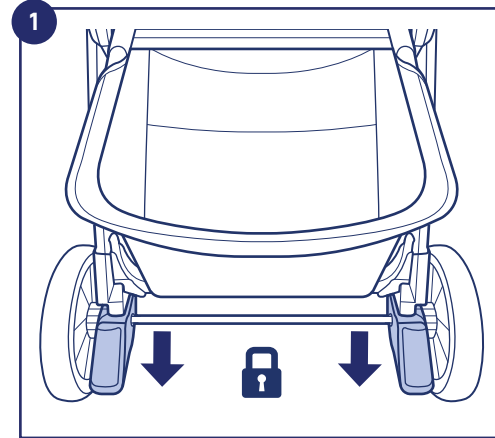

- 2** Lift the seat fabric to access the fold handle. With your thumb, slide the fold release button and rotate the fold handle to the vertical position to release the fold latch.

The stroller will start to fold when the fold latch is released.

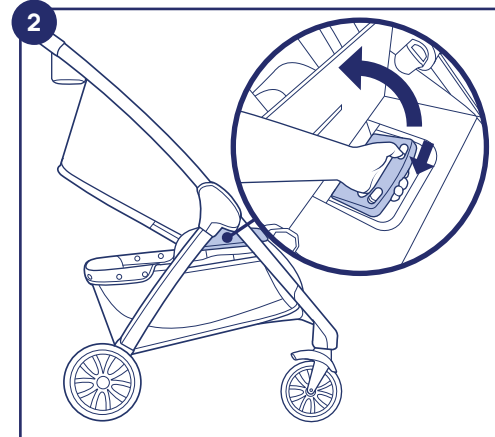

- 3** Lift the fold handle to allow the frame to fold compactly towards the rear wheels.

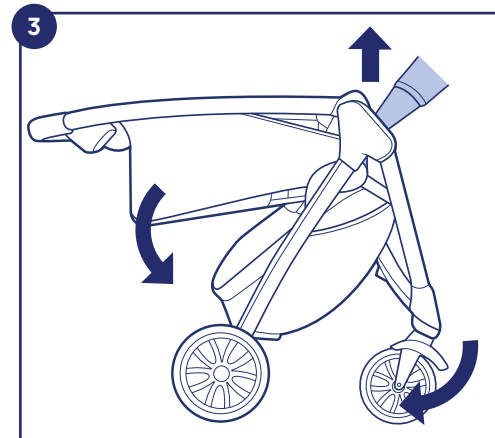

FOLDING THE STROLLER

- 4 The folded stroller will now stand on its wheels.

Note: The fold handle also acts as a carry handle after folding the stroller.

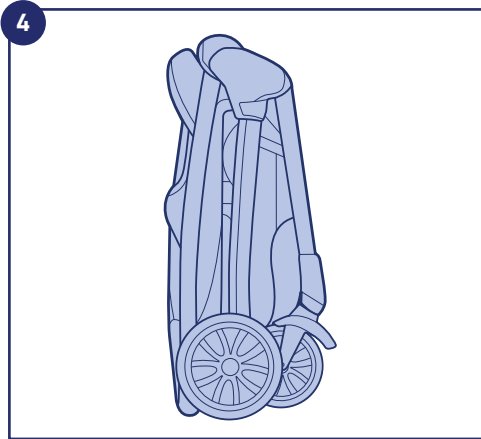

USING THE TRAVEL LOCK

- 1 The basket fob can be used as a travel lock to keep the stroller from opening.

Unclip the fob from the basket.

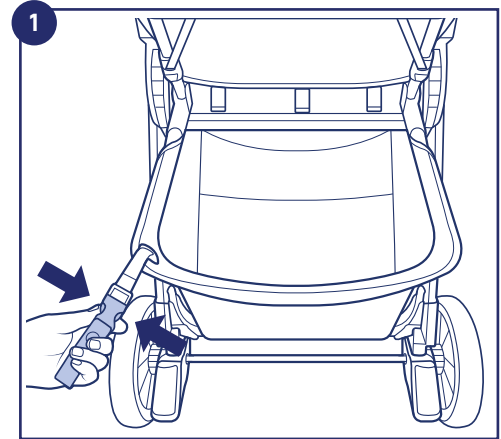

- 2 Attach the basket fob to the left side of the stroller handle using the snap.

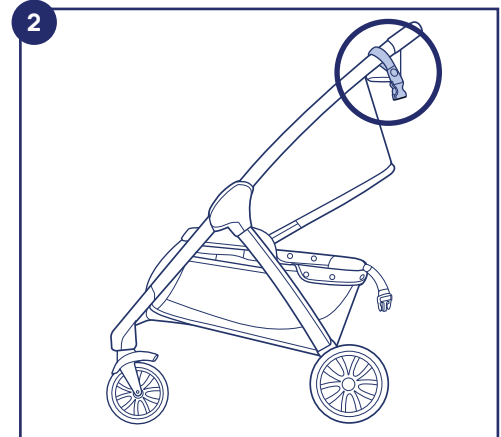

- 3 Fold the stroller and clip the fob on the handle to the clip on the basket.

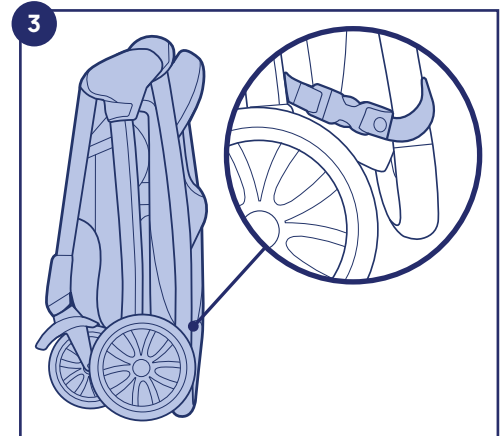

USING THE ORGANIZERS

- 1 Locate the 2 storage pockets on the inside of the back panel of the basket and the basket fob in the corner.

The basket fob can also be used as a travel lock for the folded stroller.

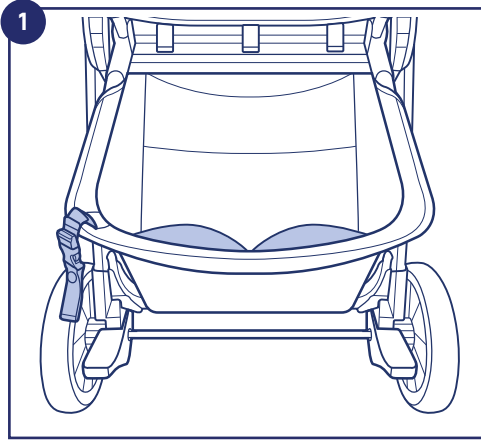

- 2 To use the accessory pocket in the parent tray, lift the front edge and undo the hook and loop fastener.

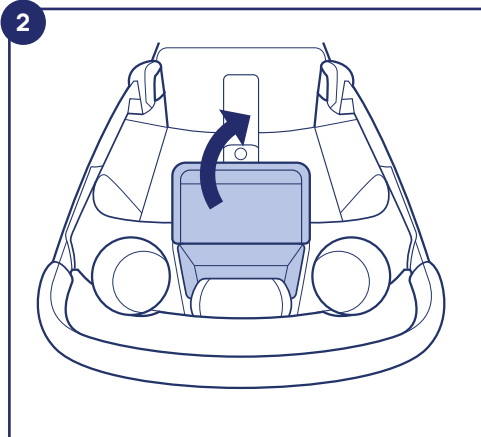

REMOVING THE SEAT FABRIC

⚠ WARNING: Never use the stroller without the seat properly attached.

- 1 To remove the seat fabric from the stroller, first remove the **child tray** and **canopy**.

From the back of the **stroller frame**, locate the 3 webbing tabs. Pinch the webbing tabs together and push them up through the seat pan.

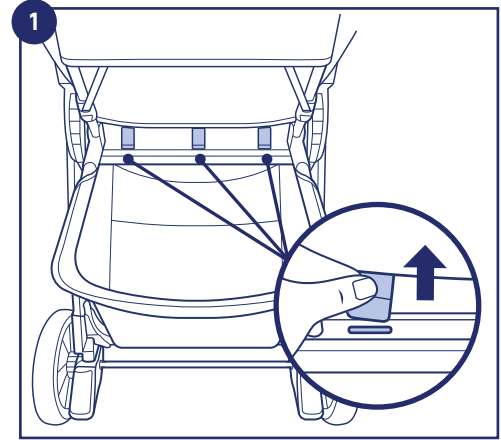

- 2 From the front of the stroller, lift the footrest and release both clips located under the seat pan.

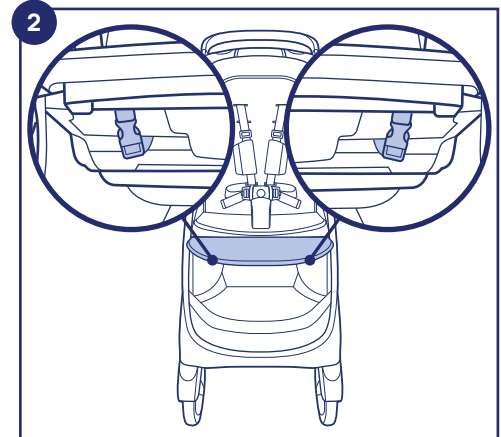

- 3 From the front of the parent tray, flex the middle of the bow down to release it from the parent tray.

Follow by lifting the bow from the channels on both sides of the parent tray.

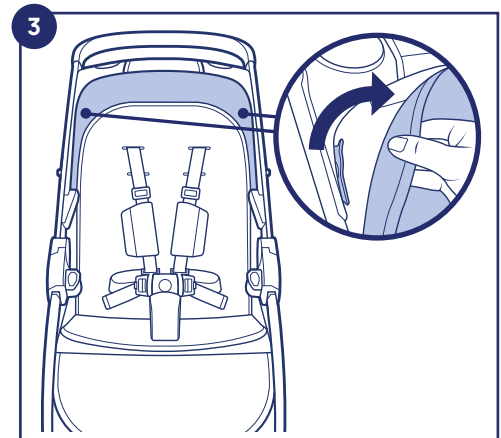

REMOVING THE SEAT FABRIC

- 4 Continue to rotate the bow forward to release it from both sides of the stroller frame.

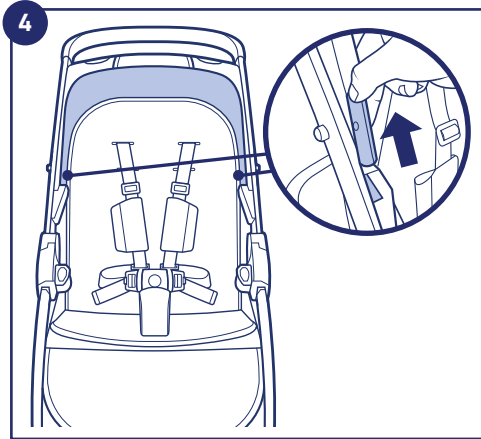

- 5 Slide the seat fabric up and over the back of the seat frame being careful to clear the recline lever.

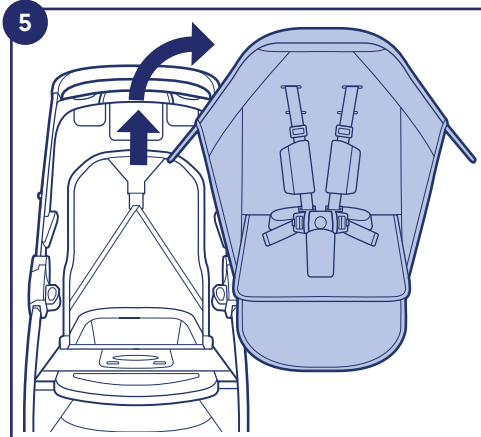

- 6 To remove the bow from the seat fabric, carefully slide the bow from the fabric tunnel.

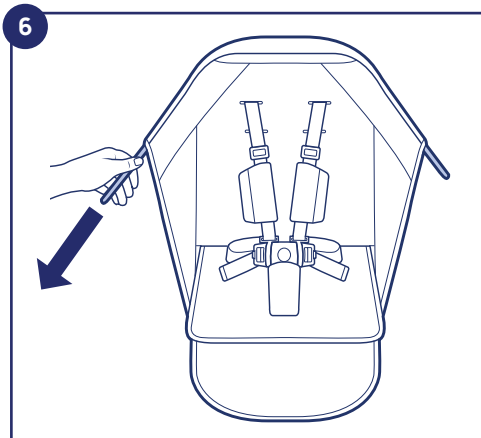

ATTACHING THE SEAT FABRIC

- 1 To reattach the seat fabric, locate the notches at the ends of the bow. With the notches to the back of the bow, insert the bow into the fabric tunnel around the top of the seat fabric.

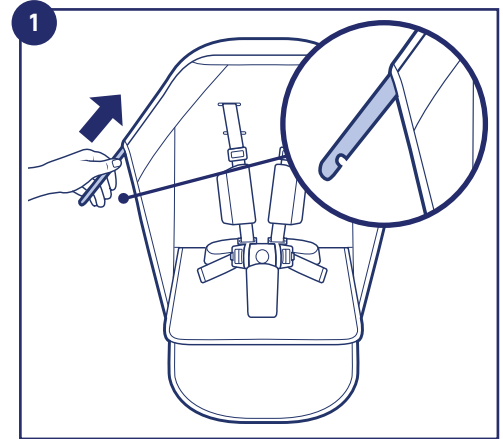

- 2 Slide the seat fabric around the seat frame and over the recline lever.

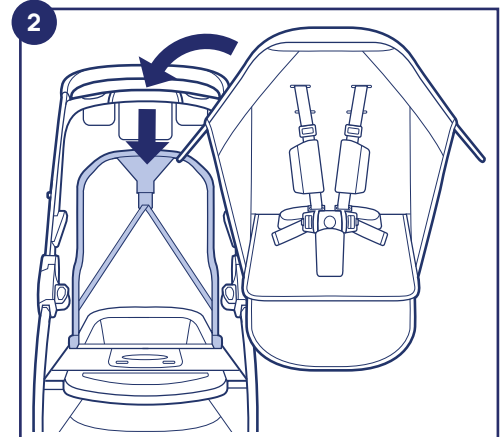

- 3 Place the ends of the bow into the openings on the stroller frame until they stop. Rotate the bow back into the frame until the bow notches are keyed into the sockets.

Continue to rotate the bow back into the stroller frame.

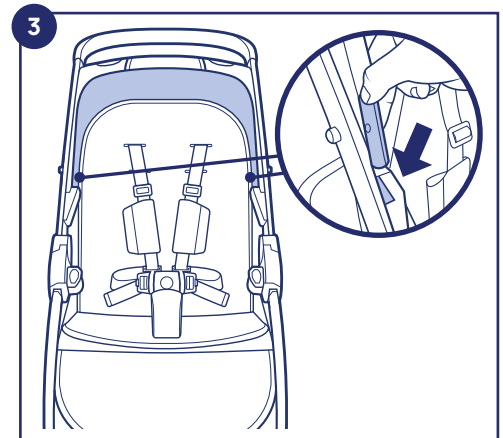

ATTACHING THE SEAT FABRIC

- 4 Insert the bow into the channels on both sides of the parent tray. From the front of the parent tray, flex the middle of the bow down to secure it under the parent tray.

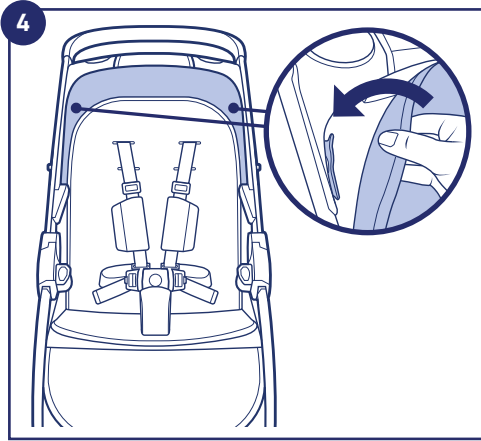

- 5 Thread the clips on the seat fabric through the seat frame.

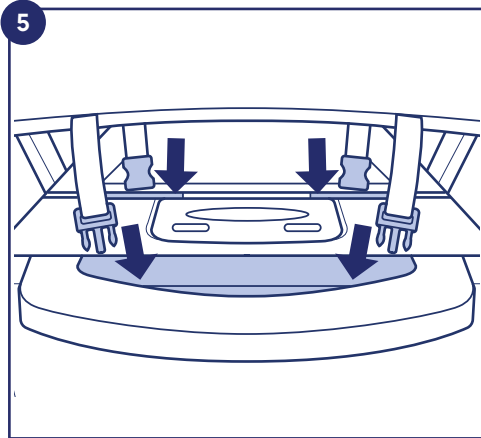

- 6 From the front of the stroller, lift the footrest and attach both clips located under the seat pan.

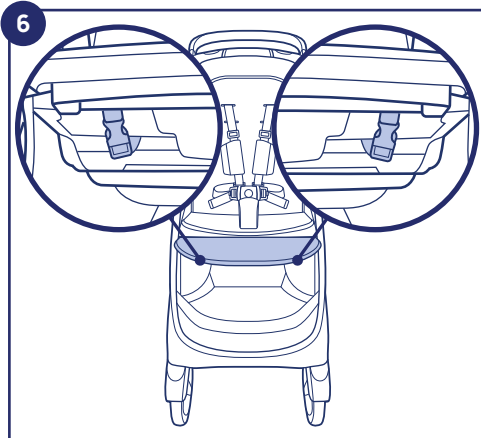

ATTACHING THE SEAT FABRIC

- 4 From the back of the stroller, locate the 3 webbing tabs on the seat fabric. Pinch the webbing tabs together and push them down through the seat pan.

Make sure all 3 tabs are securely attached to the seat pan.

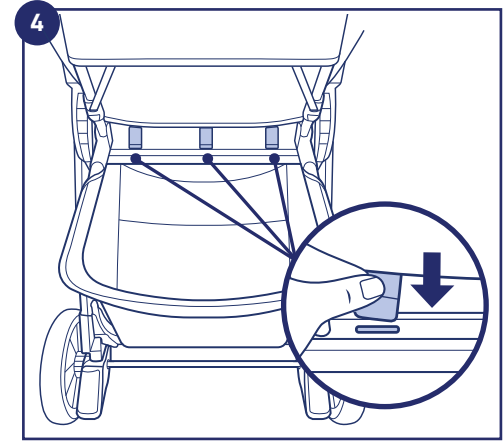

REMOVING THE ACCESSORY POCKET

- 1 To remove the accessory pocket, rotate the **canopy** forward for easier access to the parent tray. From the front of the parent tray, flex the middle of the bow down to release it from the parent tray. Follow by lifting the bow from the channels on both sides of the parent tray.

Note: The bow does not need to be removed from the stroller to remove the accessory pocket.

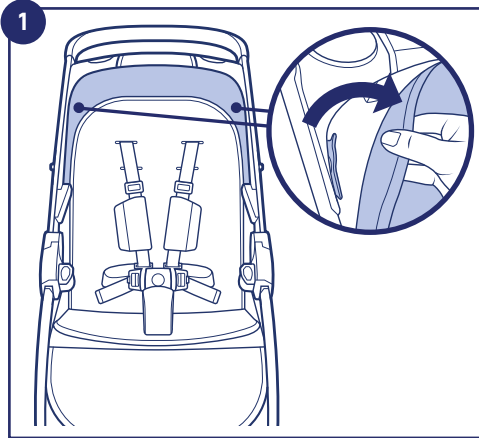

- 2 From the front edge of the parent tray, unfasten the hook and loop on the accessory pocket.

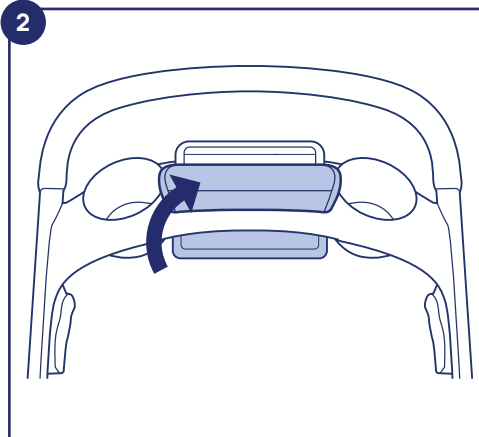

- 3 Lift the accessory pocket over the back of the parent tray. The plastic tab will release from the groove under the back of the parent tray.

To reattach the accessory pocket to the parent tray, **REVERSE** the steps.

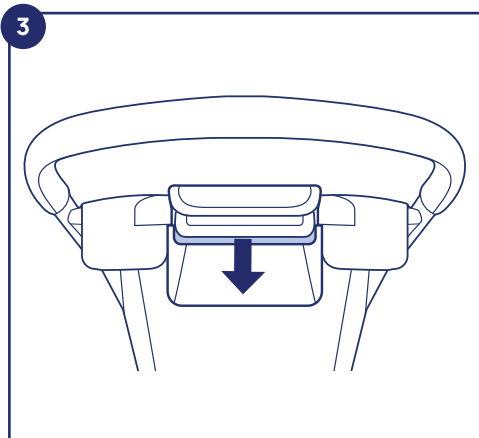

REMOVING THE BASKET

- 1 To remove the basket from the **stroller frame**, unfasten the hook and loop straps from the front of the basket and remove them from the slots on the back of the footrest.

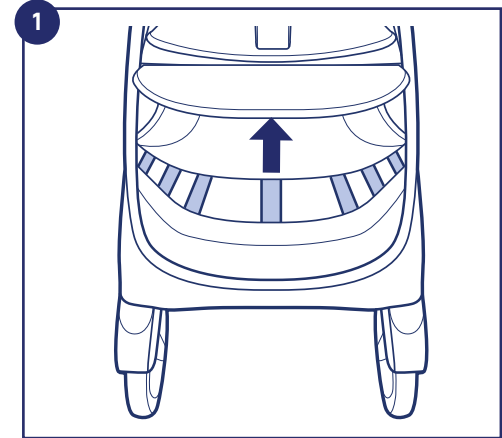

- 2 From the back of the stroller, release the 3 snaps from the bottom of the basket.

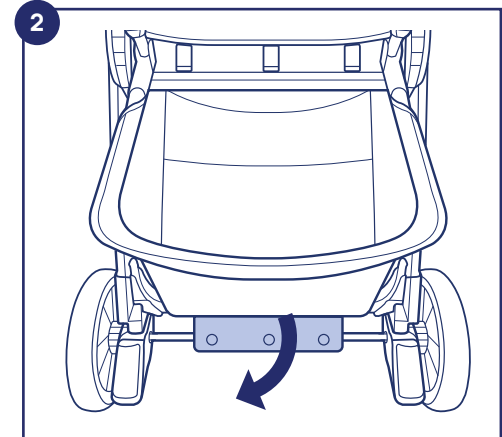

- 3 Release the snaps around the top of the basket frame.

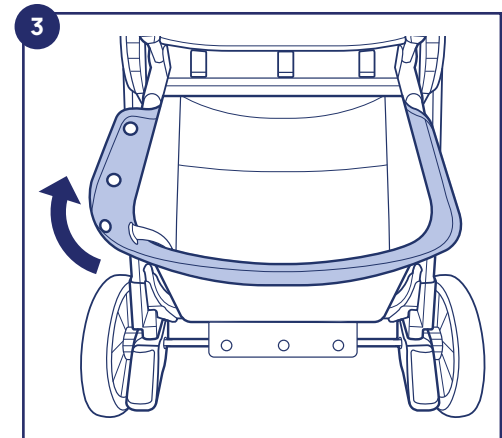

REMOVING THE BASKET

- 4 Feed the buckles of the basket fob through the button hole in the basket fabric.

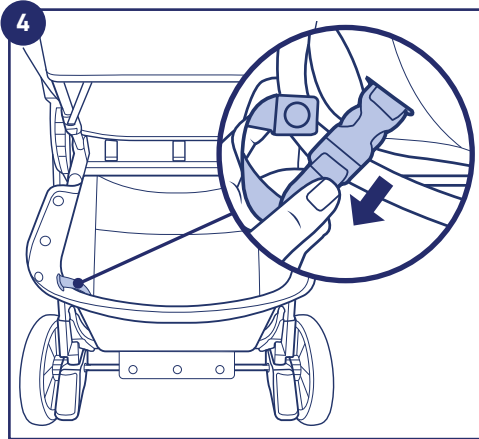

- 5 Release the snaps on the 2 basket straps at the sides of the seat pan.

Remove the basket.

To reattach the basket, **REVERSE** the steps.

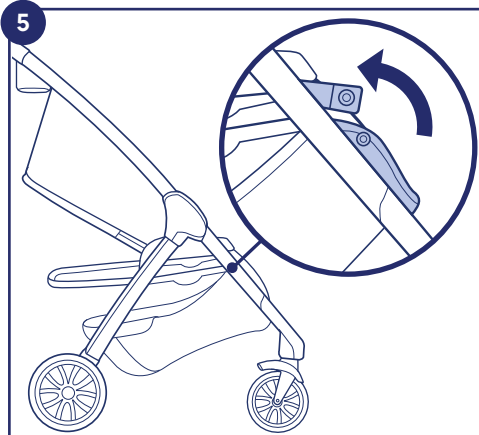

This product performs best with regular maintenance. The cleaning and maintenance of the stroller must only be carried out by an adult.

CLEANING

Spot clean fabrics using warm water and mild detergent; air dry. The shoulder pads and basket may be machine washed separately in cold water on delicate cycle using mild detergent, no bleach, and drip dry. Do not machine wash harness or seat cover.

Periodically wipe clean plastic parts with a soft damp cloth. Always dry the metal parts to prevent the formation of rust if the stroller has come into contact with water.

MAINTENANCE

Lubricate the moving parts only if necessary, with a light application of a silicone based lubricant.

Periodically check the condition of the wheels and keep them clean of dust and sand. To avoid friction that may prevent the correct operation of the stroller, ensure that all the movable plastic parts placed along the metal frame are clean of dust, dirt, or sand.

Keep the stroller in a dry place. Prolonged exposure to direct sunlight may cause the fabric to fade.



Live it. *Love it.*

If you have any problems with your Chicco stroller, or any questions regarding use, please do not return this product to the store. Contact us in one of the following ways:

Call Chicco Customer Service:

1-877-424-4226

Visit our website:

ChiccoUSA.com

Email us:

info.usa@artsana.com

[**Kee-Ko**] If you say it right it makes you *smile*

